



SPECIFICATIONS

SS-1200NS-V ThinkLink dimming DRIVER

Model: SS-1200NS-V500*

Power: 1200W

Rev.: V00

Release date: 2026-04-15

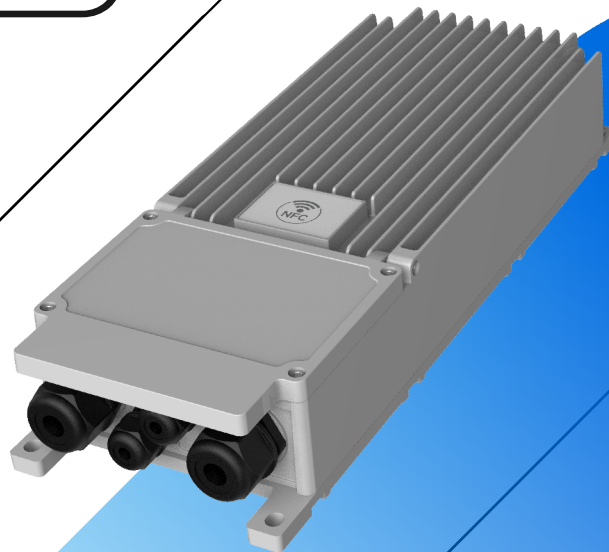

SS-1200NS-V Series ThinkLink dimming Driver

Features

- Efficiency up to 97%
- Dimming: DALI-2&D4i&DMX/RDM&0-10V&PWM&Resistor
- Independent two-channel output
- Dim-to-Off without afterglow
- Max remote distance 300 meters(dimming and output)
- DMX/RDM control up to 44fps
- AUX Power: 24V/125mA
- Time-Controlled Dimming/EOL/CLO/NTC
- Built-in DALI-2 bus power supply
- Dim-to-off & Standby power≤0.5W @230Vac
- Protections: SCP/OTP/OVP/OPP
- NFC programmable
- Built-in AC power metering with up to ±1% accuracy
- Dimming Range: minimum to 0.1%
- Surge protection: CM: 10kV, DM: 10kV
- IP66 IK08
- Warranty: 5 years

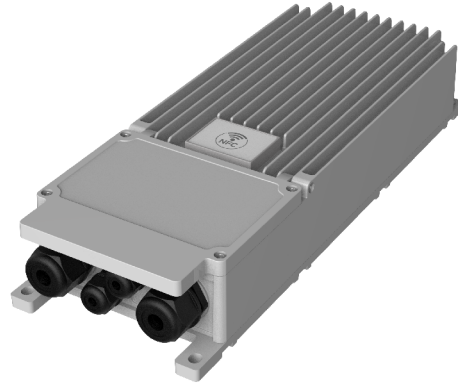

Description

The SS-1200NS-VXX is a 1200W intelligent LED driver designed for advanced smart lighting applications. Supporting D4i (DALI-2), DMX/RDM, 0-10V, PWM, and resistor dimming, it is compatible with a wide range of lighting systems and controllers. It offers real-time power and brightness adjustment, scene configuration, fault monitoring, and remote management. Combined with multiple protection features, high conversion efficiency, and stable output performance, it ensures reliable operation for LED luminaires. Applications: Stadium lights, High mast lights.

Model List:

Model	AC Input Range	Max. Pout	O/P Channel	Vout Range	Recommended Voltage	Iout	Pout (Max)	THD (Typ.)	PF (Typ.)	Eff. (Typ.)	Max.Tc
SS-1200NS-V500MN	180-528Vac	1200W	CH1	150-500V	252-500V	0.35-2.38A	600W	10%	0.95	97%	90°C
			CH2	150-500V	252-500V	0.35-2.38A	600W				

Note:

1.Default Tested: at 480Vac, full load, Ta 25°C;

2. The performance of the LED Driver can be guaranteed within the full power Vo range. The voltage lower than full power Vo range, it is need to test the performance with the LED module ;

SS-1200NS-V Series ThinkLink dimming Driver

Input Characteristics:

Parameter	Min.	Typ.	Max.	Remark
Rated AC Input Range	200Vac		480Vac	@Ta:50°C
AC Input Range	180Vac		528Vac	Reference derating curve
Input Frequency Range	47Hz	50/60Hz	63Hz	
Max Input Current			7.25A	200Vac, Full load
Max Input Power			1450W	200Vac, Full load
Max Inrush Current(220Vac)			15A	Cold start
Max Inrush Current(277Vac)			18A	Cold start
Max Inrush Current(347Vac)			20A	Cold start
Max Inrush Current(400Vac)			23A	Cold start
Max Inrush Current(480Vac)			25A	Cold start
Standby Power			0.5W	When the DALI bus power is off, 230Vac/50Hz, dimming off, D4i turns off the constant current source.
Power Factor	0.95	0.97		220Vac/50Hz, Full load
	0.90			200-480Vac, 70-100% load
THD		8%	10%	347Vac/60Hz, Full load
			20%	200-480Vac, 70-100% load

SS-1200NS-V Series ThinkLink dimming Driver

O/P Characteristics:

Parameter	Min.	Typ.	Max.	Remark
O/P Voltage Range	150V		500V	CH1/CH2, Power derated @150-252V
Rated O/P Voltage	252V		500V	CH1/CH2, Po=Vo*Io=600W, Full load
Rated O/P Current	1.2A		2.38A	CH1/CH2, 2.38A for 252V, 1.2A for 500V
Adj. O/P Current (AOC) Range	0.35A		2.38A	CH1/CH2, Adjustable by program
No Load Voltage			600V	CH1/CH2,
Efficiency @220Vac	94.0%	96.0%		CH1/CH2, O/P 500V/1.2A
Efficiency @400Vac	95.0%	97.0%		CH1/CH2, O/P 500V/1.2A
Efficiency @480Vac	95.0%	97.0%		CH1/CH2, O/P 500V/1.2A
O/P Current Tolerance	-5%		+5%	
O/P Current Ripple(PK-AV)		2%	5%	Full load
>3000Hz O/P Current Ripple (PK-AV)		1%Iomax		70-100% load
Start-up Current Overshoot			10%	Full load
Start-up Time			0.65S	Operating in DMX/RDM/ Time-controlled dimming mode, at 200-480Vac, 40%-100% load
			1.0S	Operating in DALI-2 Dimming mode at 200-480Vac, 40%-100% load.
Line Regulation	-3%		+3%	Full load
Load Regulation	-3%		+3%	
OTP	90°C	95°C	100°C	Drop current when OTP, and it can be automatically restored after the abnormality is removed.
Short Circuit Protection				Driver will not be damaged, Constant current mode
AC power metering accuracy	-1%		+1%	400Vac, 100% load

SS-1200NS-V Series ThinkLink dimming Driver

Dimming Characteristics:

Parameter		Min.	Typ.	Max.	Remark
0-10V Dimming (Optional)	Dim Vmax	0V		12V	Negative dimming by programming Dimming prohibits reverse connection. DIM+ source current 110uA .
	Dim Range	10%loset		100%loset	
	Rec.Dim Range	0V		10V	
0-10V Dimming (Optional)	Rec.Dim Range	0V		10V	DIM+ Maximum sink current is 40uA Dimming prohibits reverse connection. 5-0V by programming
PWM Dimming (Optional)	PWM High	9.8V		10.2V	
	PWM Low	0V		0.3V	DIM+ source current 110uA .
	Frequency	1KHz		2KHz	Dimming prohibits reverse connection.
	PWM Duty	0%		100%	
Resistor Dimming (Optional)	Resistance	0Kohm		100Kohm	
	Dim Range	10%loset		100%loset	DIM+ source current 110uA .
0-10V Dim to Off	Dim off	0.7V	0.8V	0.9V	By DC voltage, PWM, resistance dimming ratio
	Dim on	0.8V	0.9V	1.0V	By DC voltage, PWM, resistance dimming ratio
DMX/RDM	DMX+ to DMX-	-6V	—	6V	
	DMX+ to Case	22M ohm	—	—	
	DMX- to Case	22M ohm	—	—	
	Input Logical 0	—	—	-0.2V	DMX+ to DMX-
	Input Logical 1	0.2V	—	—	DMX+ to DMX-
	Baud rate	—	250K bps	—	
DALI-2	DA+, DA- High Level	9.5V	16V	22.5V	
	DA+, DA- Low Level	-6.5V	0V	6.5V	
	DA+, DA- Current	0mA		2mA	
Dimming Output Range	SS-1200NS-V500MN	0.1%loset		loset	1800mA ≤ loaset ≤ 2380mA
		0.4%loset		loset	1200mA ≤ loaset ≤ 1799mA

SS-1200NS-V Series ThinkLink dimming Driver

Dimming Characteristics:

Parameter		Min.	Typ.	Max.	Remark
Aux Power	Rated O/P Voltage	21.6V	24V	26.4V	The reference ground is "DA-"
	Rated O/P Current	0		125mA	The reference ground is "DA-"
	Peak O/P Current	0		250mA	The reference ground is "DA-". During a 6ms period, maximum duration of 250mA peak output current 2.2ms, and the average value cannot exceed 125mA.
Integrated DALI-2 Bus Power Supply Voltage		12V	16V	20V	
Integrated DALI-2 Bus Power Supply Current		50mA		60mA	
Life Time(Tc=75°C)		80,000 hours			80% load 480Vac
MTBF		198,800 hours			480Vac,80% load, Ta=25°C (MIL-HDBK-217F)
IP Grade		IP66			
Tc		90°C			
Warranty		5 years			Tc:80°C
Net Weight		5440g			
Dimension		410mm*150mm*72mm			L x W x H

NOTE:

1. All the parameters above are tested Ta 25°C and LED load, unless specified.
- 2.The DALI-2 bus power supply is enabled by default and can be disabled using a programming tool or NFC programming.

SS-1200NS-V Series ThinkLink dimming Driver

Environmental Requirements

Parameter	Min.	Typ.	Max.	Remark
Operating Temperature(Tcase)	-40°C	25°C	+90°C	
Storage Temperature	-40°C	25°C	+90°C	
Operation Humidity	10%RH		90%RH	
Storage Humidity	5%RH		95%RH	

Safety and EMI/EMS Standards

Certification	Standard	Status	Remark
UL	UL8750		
CUL	CAN/CSA C22.2 No.250.13		
ENEC	EN 61347-1 EN 61347-2-13 EN IEC 62384		
RCM	AS/NZS61347.2.13		
CCC	GB/T 19510.1 GB/T 19510.213		
CE	EN 61347-1 EN 61347-2-13 EN 62493		
	EN 301 489-1 EN 301 489-3 EN 300 330 EN 62479/EN 50663/EN 50665/EN 50364		For NFC wireless products

SS-1200NS-V Series ThinkLink dimming Driver

Safety and EMI/EMS Standards

EMI/EMS	Standard	Status	Remark
Conduction Emission	EN IEC 55015		
	GB/T 17743		
	FCC Part 15 Subpart B;ANSI C63.4		ClassB
Radiation Emission	EN IEC 55015		
	GB/T 17743		
	FCC Part 15 Subpart B;ANSI C63.4		ClassB
Harmonic Current Emissions	EN IEC 61000-3-2		ClassC
	GB 17625.1		ClassC
Surge	IEC/EN61000-4-5		DM:10kV,CM:10kV,Criterion B
	ANSI/C82.77-5		DM:6kV,CM:6kV,Criterion B
Ring Wave	IEC/EN 61000-4-12		DM:6kV,CM:6kV,Criterion B
	ANSI/C82.77-5		DM:6kV,CM:6kV,Criterion B

DALI-2 Standard	Remark
DALI-2 ⁽¹⁾	IEC 62386-101,-102 & -207

Note ⁽¹⁾DALI parts:101,102,150,207,250,251,252,253

SS-1200NS-V Series ThinkLink dimming Driver

Safety Test Items:

Safety Test Items	Technical Indicators			Remark
Insulation Requirements	UL Insulation Requirements	ENEC Insulation Requirements	CCC Insulation Requirements	
Input-Case	2U+1000Vac	2U+1000Vac	2U+1000Vac	Basic insulation
Input-Dim	2U+1000Vac	4U+2000Vac	4U+2000Vac	UL Basic insulation,ENEC and CCC Reinforced insulation
Dim-Case	2U+1000Vac	2U+1000Vac	2U+1000Vac	Basic insulation
Insulation Resistance	$\geq 10M\Omega$			Input-Dim,Test voltage:500Vdc
Ground Resistance	$\leq 0.1\Omega$			25A/1min
Leakage Current	$\leq 0.7mA$			IEC 60598-1;480Vac/60Hz, Effectively grounded

NOTE:

1. SOSEN warrants the LED Driver itself complies with EMC standard. However, LED Driver's EMC should be re-checked when integrated into lighting systems due to unexpected interference as components.
2. Please short(ACL and ACN),(V+ and V-,NTC+/NTC-),(DA+ and DA- and Vaux+) when Hi-pottest (Turn off ARC).
3. When grounding, the input and output lines need to be short-circuited together.

Performance Curves:

Input Inrush Current

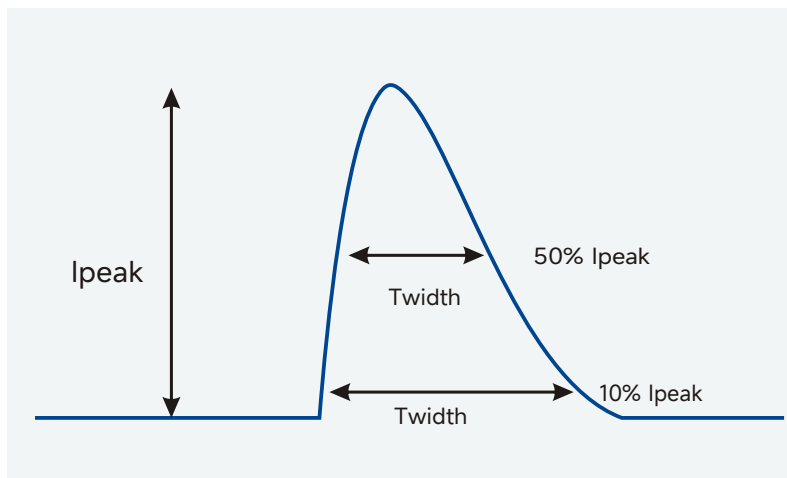

Vin	Ipeak	T(@10% of Ipeak)	T(@50% of Ipeak)
220Vac	15A	10mS	5mS
277Vac	18A	14mS	6mS
347Vac	20A	16mS	7mS
400Vac	23A	18mS	8mS
480Vac	25A	20mS	9mS

SS-1200NS-V Series ThinkLink dimming Driver

Performance Curves:

O/P Voltage Vs. O/P Current(Dim/AOC Window)

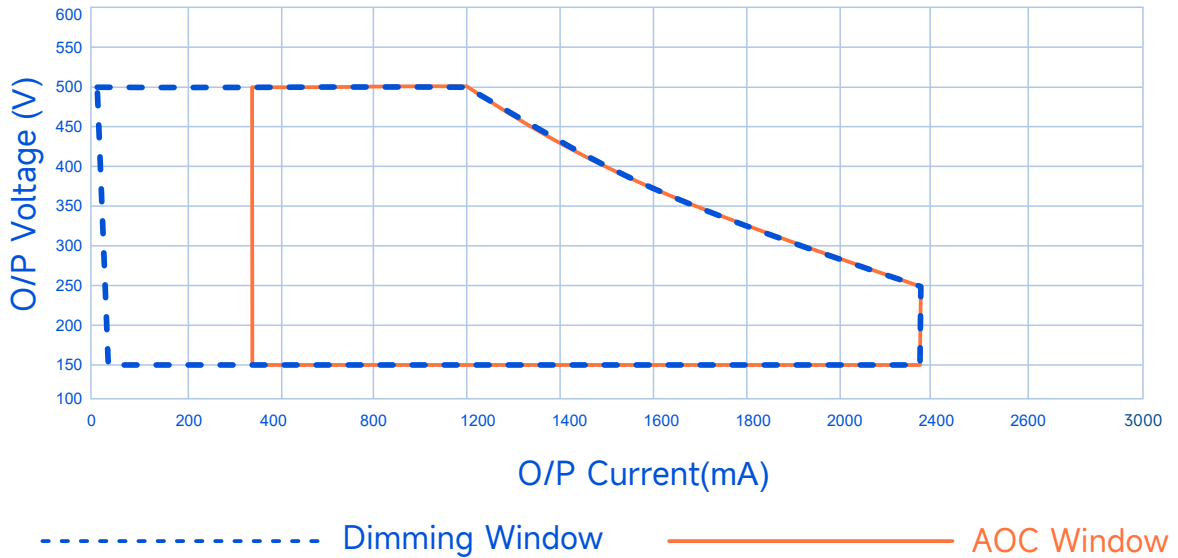

O/P Voltage Vs. O/P Current(Dim/AOC Window)-CH2

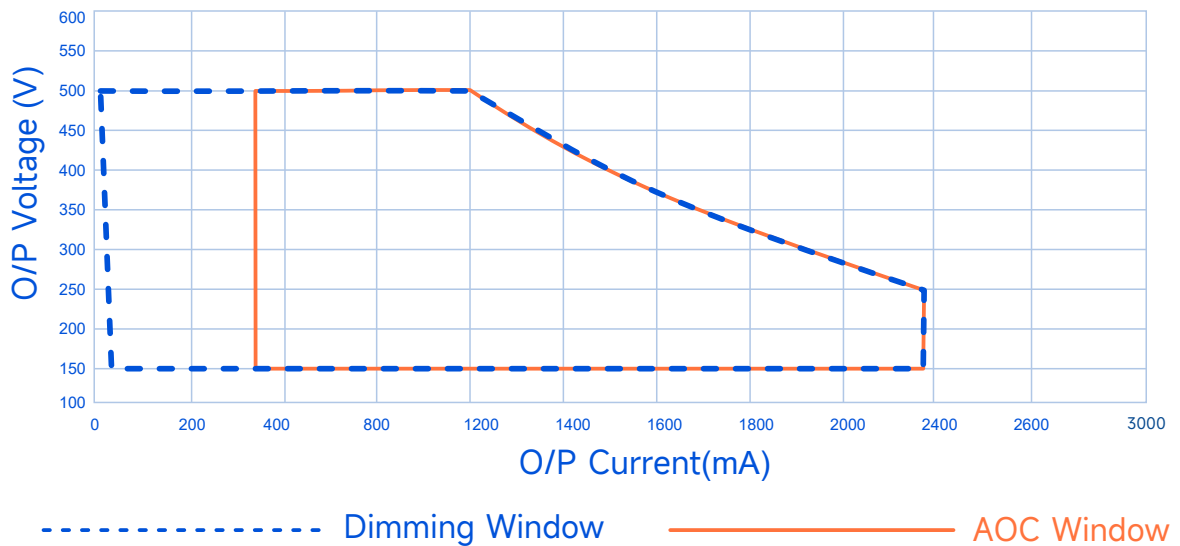

SS-1200NS-V Series ThinkLink dimming Driver

Performance Curves:

Efficiency Vs. O/P Voltage ($V_{in}=220V_{ac}$)

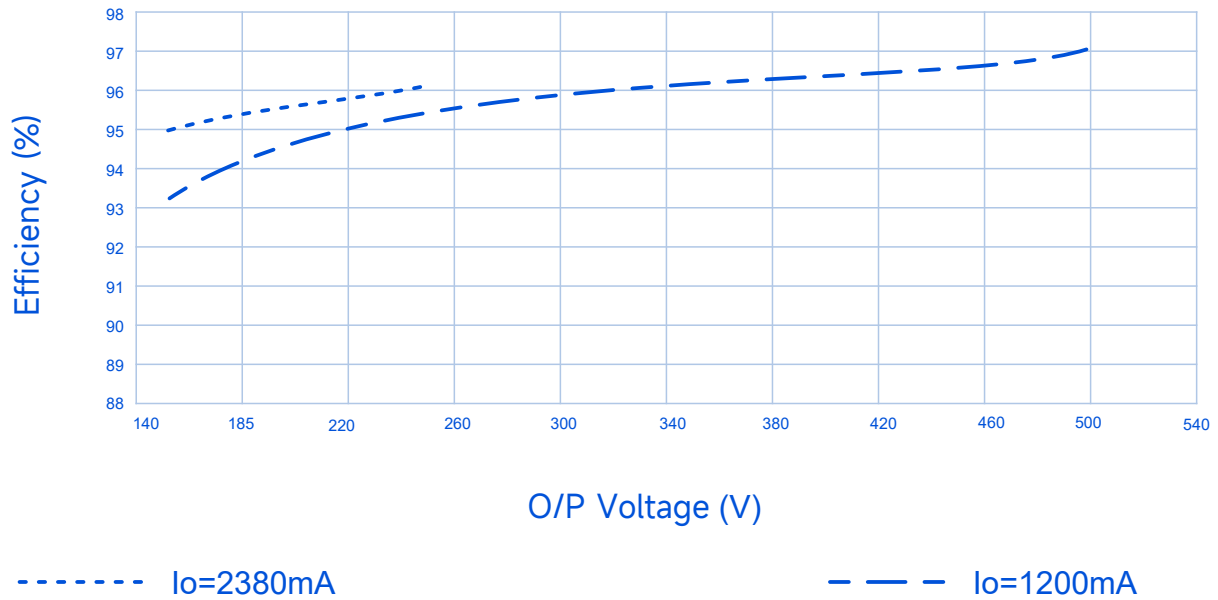

Efficiency Vs. O/P Voltage ($V_{in}=400V_{ac}$)

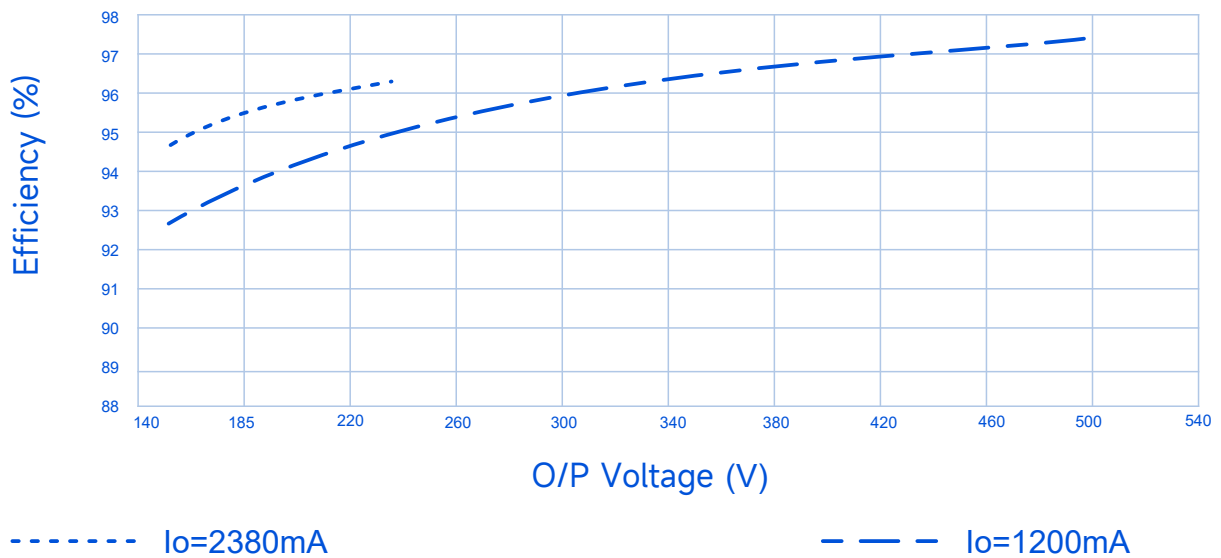

SS-1200NS-V Series ThinkLink dimming Driver

Performance Curves:

Efficiency Vs. O/P Voltage ($V_{in}=480V_{ac}$)

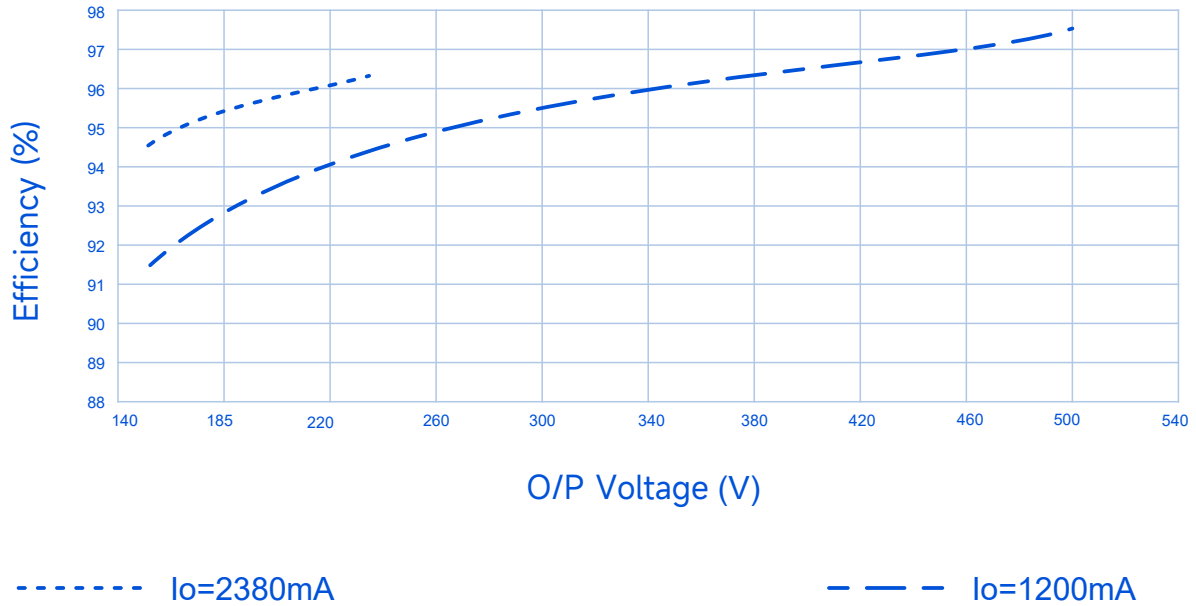

SS-1200NS-V Series ThinkLink dimming Driver

Performance Curves:

Power Factor Vs. Output Power

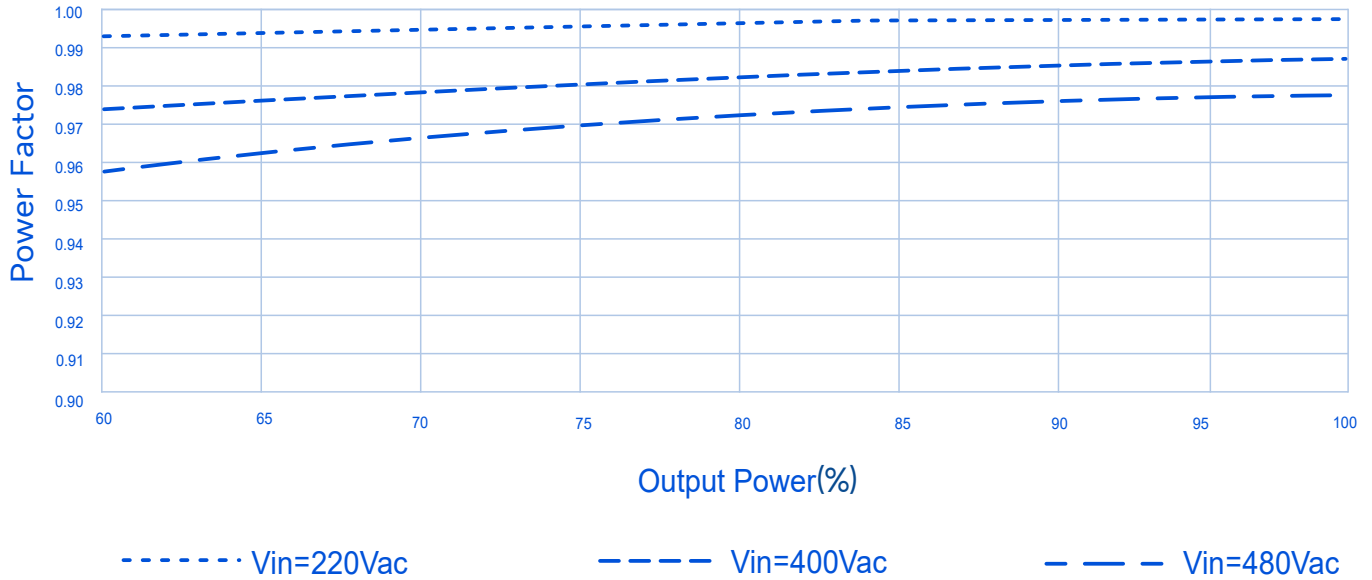

THD Vs. Output Power

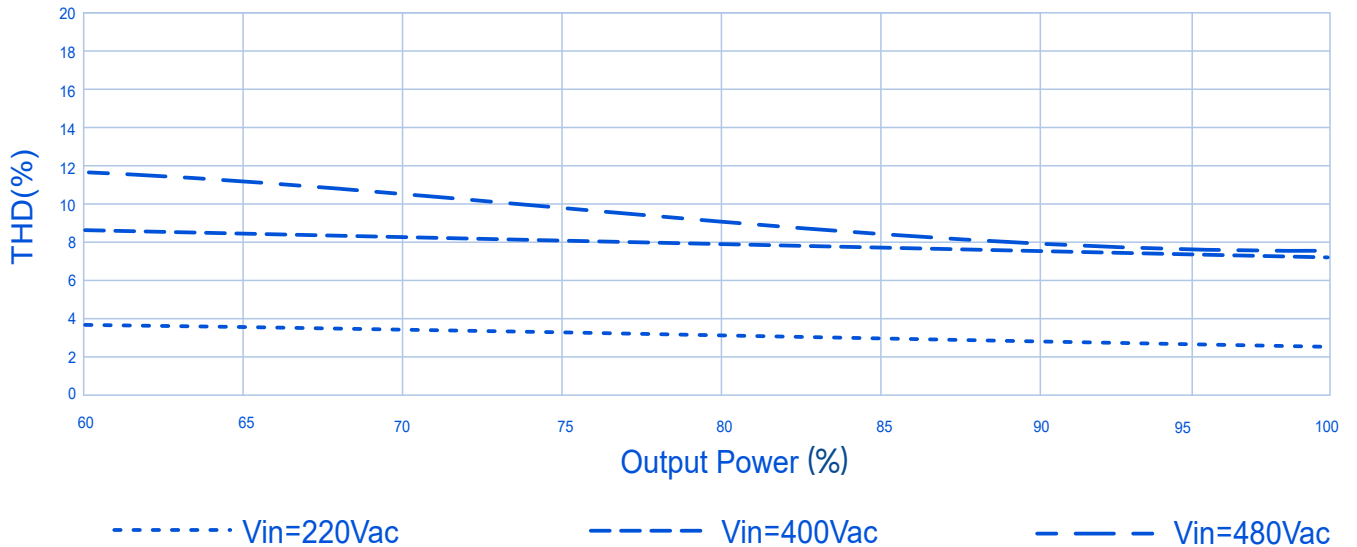

SS-1200NS-V Series ThinkLink dimming Driver

Performance Curves:

Output Power Vs. Input Voltage

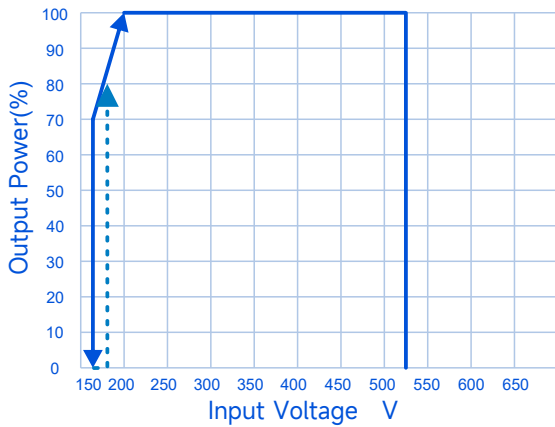

Lifetime Vs. Case Temperature

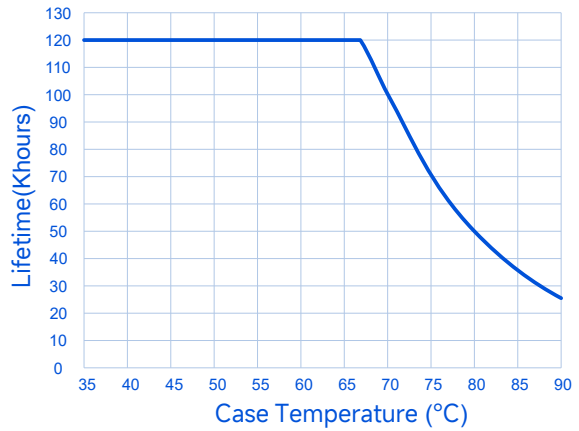

O/P Power Vs. Case Temperature

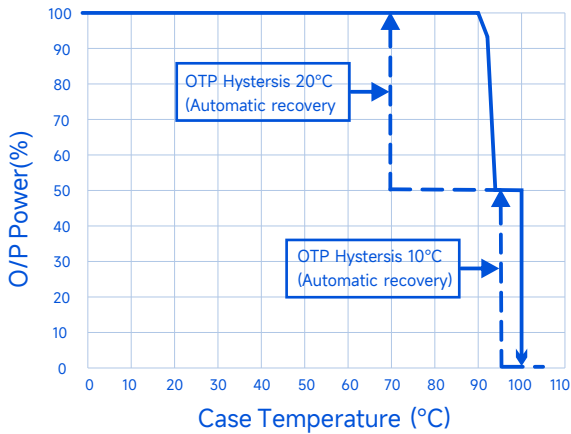

Logarithmic Dimming Curve (DALI-2/DMX model)

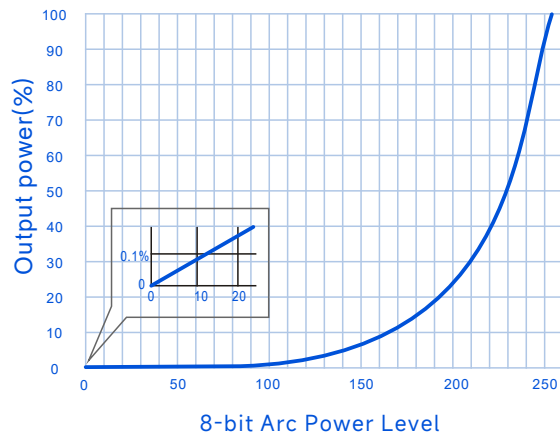

Output Power Vs. Dimming

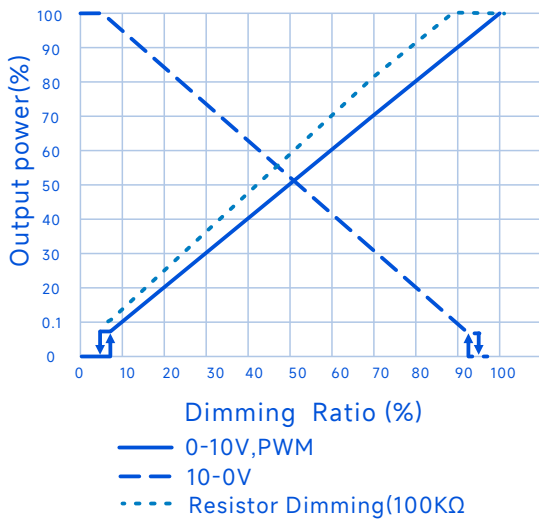

Linear Dimming Curve (DALI-2/DMX model)

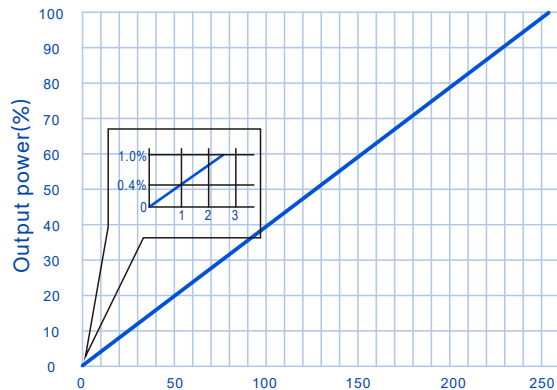

External heat protection

The overheat protection of an LED luminaire shall be implemented by an external circuit installed at the hottest part of the luminaire, so as to protect the entire luminaire when the temperature exceeds the rated value. This protection circuit shall be connected to the V+ and NTC terminals of the LED driver. The default protection temperature threshold is 100°C, which can be adjusted via the Sosen PC Software according to the actual on-site application requirements.

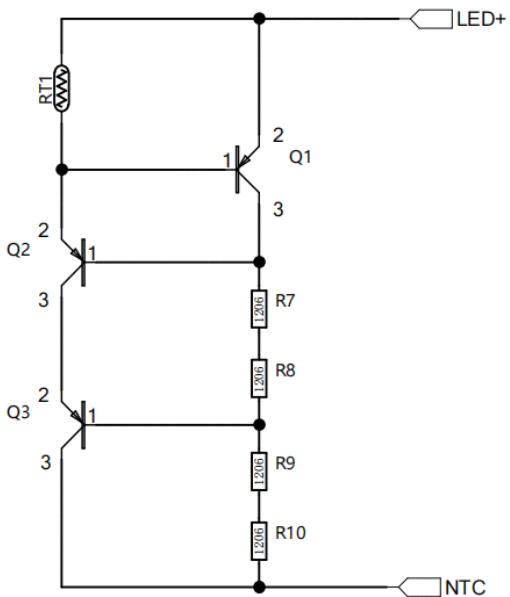

Reference	Description	Recommendation
Q1/Q2/Q3	500V PNP high-voltage transistor	FZT560, SOT-223, DIODES
RT1	NTC 10KΩ	0603 SMD 1% TDK b57371v2103h060 B(25/100)=4480
R7/R8/R9/R10	510KΩ Resistor	510KΩ 1% -55~155°C 1206

TLED(°C)	70	90	100	105
NTC value(Ω)	1426	685	488	415
IOUT(%)	100	10	10	10

Note:

This protection is optional, and users can leave the NTC port hanging when they do not use this function.

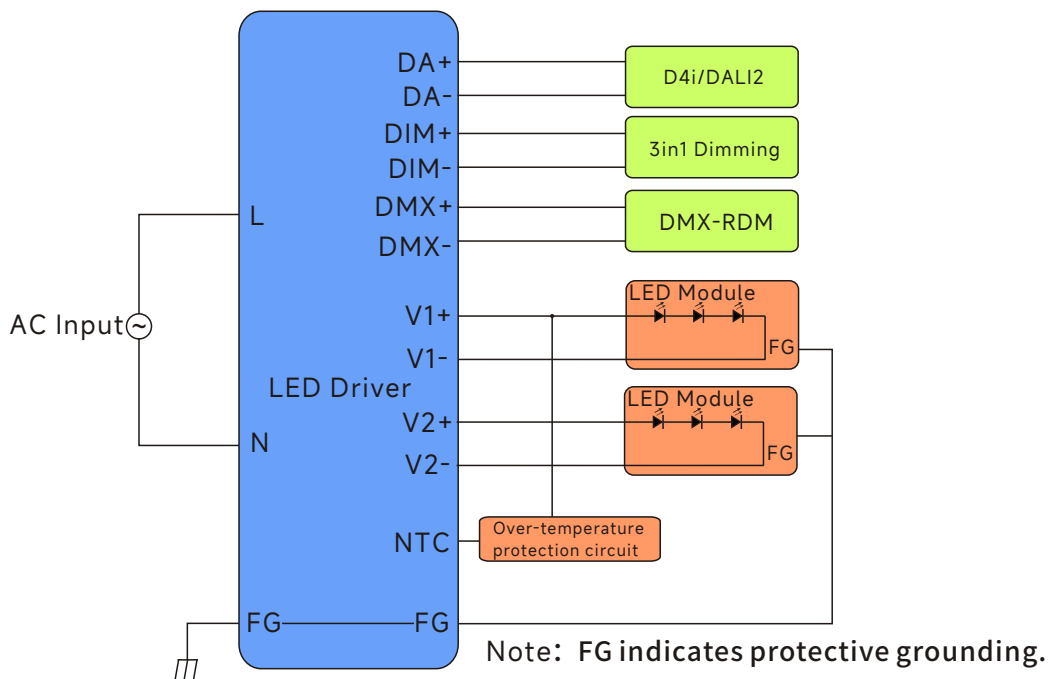

Note: FG indicates protective grounding.

SS-1200NS-V Series ThinkLink dimming Driver

Strobe function

The LED driver supports the strobe function in DMX/RDM mode. The frequency can be set within the range of 0.1-22 Hz, which corresponds to a maximum adjustable frame rate of 44 fps (frames per second). The dimming level cycles repeatedly between 100% and 0%. To improve the reliability of the output relay, the relay remains in a closed state while the strobe function is activated, and thus will not undergo frequent switching on and off.

Timer Dimming

Automatic conversion between DST and Standard Time. Traditional Timer Dimming, Self-Adapt-Midnight Timer, Self-Adapt-Percentage Timer. The time dimming percentage can be set by setting 8 curves.

Traditional timer: After power-on, it works according to the set timing curve (Increasing fade time allows for slow changes between different dimming levels, preventing sudden changes in brightness and causing dazzle)

Self Adapting-Midnight: Automatically save power-on times and use 4 valid timers to assume that the center point of the dimming curve is local midnight time.

Self Adapting-Percentage: Runs the initially set dimming curve according to an automatically calculated adaptive cycle time.

CLO Constant Lumen Output

Light failure compensation function, in the Luminaire life cycle, by gradually increasing the output current, to achieve a constant output of LED luminous flux, the overall luminous effect remains unchanged.

ELA End-of-Life Alert

By presetting a LED driver life time, such as 50KH, after the luminaire has accumulated 50KH of light-up time, every time the luminaire is powered on, it will blink 4 times to remind the user to replace the LED driver.

Programming connection diagram

NFC programming

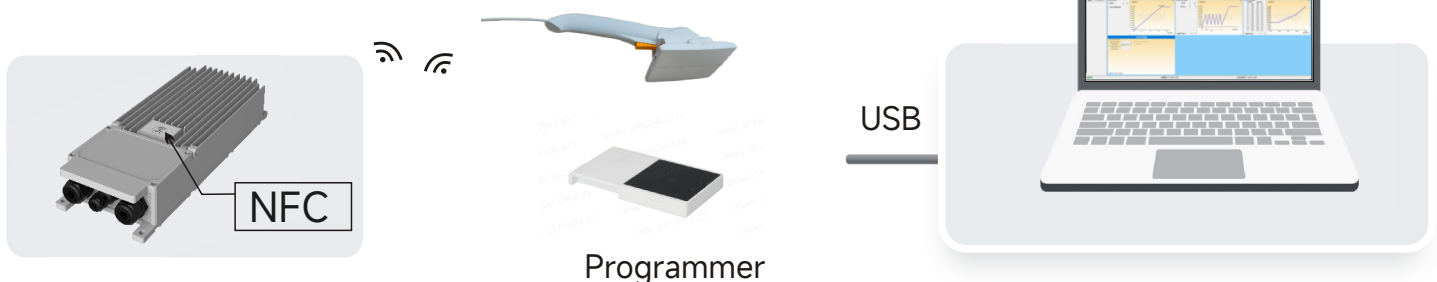

Note

1. Power must be disconnected during NFC programming; otherwise, the programming data cannot be saved.
2. Use a handheld or board-type programmer to program the area directly above the NFC..

SS-1200NS-V Series ThinkLink dimming Driver

Mechanical Characteristics

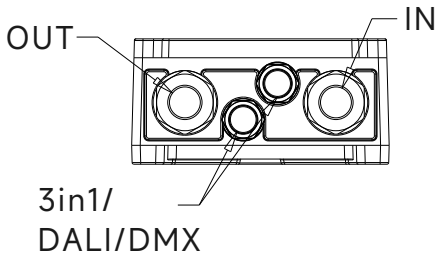

Function Definition	Cable Gland	Recommended Wire Diameter (mm)	Wire Marking (AWG)	Wire Cross-Sectional Area (mm ²)	Strand Length(mm)
AC Input	M25	13-18	14-16	1.5-2.5	9-10
DC Output	M25	13-18	14-16	1.5-2.5	
DALI	M16	4.5-8.5	16-18	0.75-1.5	
DMX					
DALI Cascade	M16	4.5-8.5	16-18	0.75-1.5	
DMX Cascade					

Terminal diagram

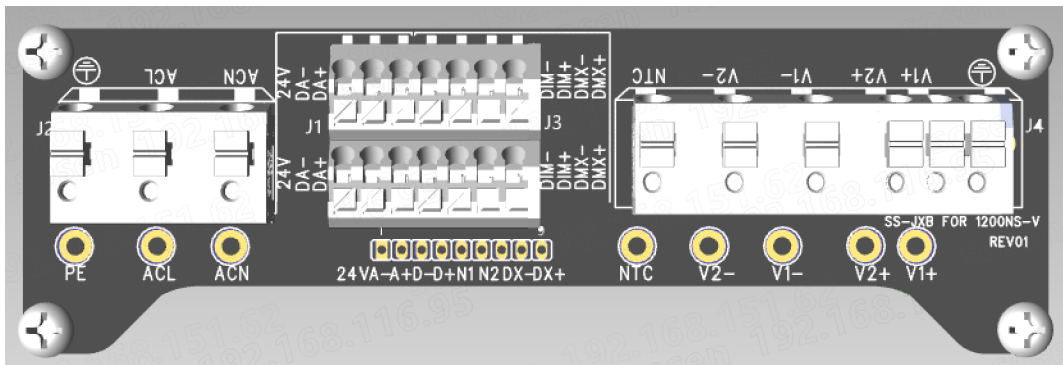

NO.	LABEL	FUNCTION
1	⊕	PROTECTION EARTH
2	ACL	AC INPUT L/L1
3	ACN	AC INPUT N/L2
4	24V	AUX POWER
5	DA-	DALI-
6	DA+	DALI+
7	DMX-	DMX-
8	DMX+	DMX+
9	DIM-	3IN1 DIM-
10	DIM+	3IN1 DIM+
11	NTC	LED LIGHT THERMAL PROTECTION INPUT
12	V2-	LED- CONNECTION
13	V1-	LED- CONNECTION
14	V2+	LED+ CONNECTION
15	V1+	LED+ CONNECTION
16	⊕	PROTECTIVE EARTH FOR LED MODULE

SS-1200NS-V Series ThinkLink dimming Driver

Mechanical Characteristics

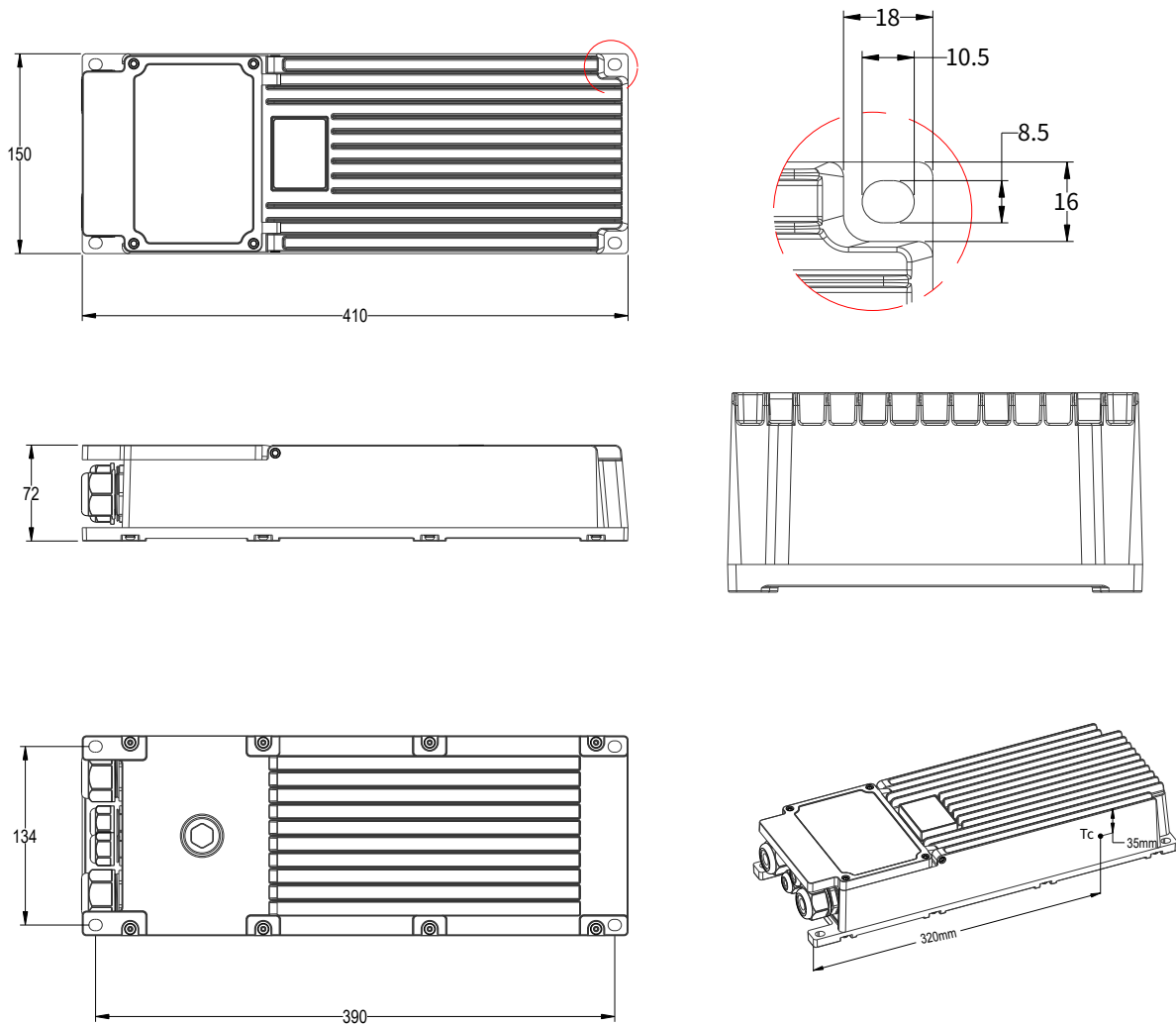

SS-1200NS-V Series ThinkLink dimming Driver



Assembly Tips

1. Dimming or AUX Power tinned connectors should be capped if not used to avoid dimming or AUX Power parts damage from external signals.
2. The trace routing on aluminum substrates is designed in compliance with creepage distance requirements specified by relevant certification regulations.
3. The creepage distance between LED+ and LED- on the aluminum substrate is designed in compliance with the relevant certification regulations.
4. Minimize the copper area on the aluminum PCB to reduce parasitic capacitance and leakage current.
5. It is recommended to design LED beads in parallel first and then in series.
6. The insulation level of LED light panels should meet the reliability design requirements.
7. It's recommended to add resistors or capacitors in parallel with the LED on PCB to reduce the risk of surge when a non isolated LED driver is used for the luminaire
8. For other precautions, please refer to the "LED Driver User Manual" and "SOSEN LED driver Product User Guide NS-V Non-isolated Series 5-in-1 Intelligent LED Driver".

Warning

Insufficient or compromised insulation voltage resistance in LED light panels may cause breakdown and short circuits to earth, resulting in damage to the luminaire and LED driver, and posing significant safety hazards. It is recommended to install a residual current device (RCD) during application.

Package

- Outside carton dimension: L×W×H =495mm×385mm×162mm;
- 2PCS/Carton;
- Net weight/Piece: 5.44kg;Gross weight/Carton:12.48kg;
- Please refer to the product name, model number, manufacturer identification, QC PASS, manufacturing date on the package.

Transportation

Packaging is designed suitable for transportation by trucks, vessels and flights. The products should be avoided direct sunlight and rain, loaded/unloaded with caution.

Storage

The product storage meets the standard of the GB 3873-83.
Products should be rechecked if stored for over 1 year before assembly.

RoHS

Products comply with RoHS Directive (2011/65/EU) and amendment 2015/863/EU.

Revision History

Version	Description of Update	Updated Date	Remark
V00	Original Release	2026/04/15	